

# HDCD<sup>®</sup> EQUIPMENT CERTIFICATION PROCEDURE

## PACIFIC MICROSONICS, INC.

32990 Alvarado Niles Rd. • Suite 910 • Union City, CA • 94587  
Phone (510) 475-8000 • Fax (510) 475-8005

PMI #9300-0007 - Rev 2.20  
Revised on 5.28.99

© 1996,1997,1998, 1999 Pacific Microsonics, Inc. All rights reserved.

The contents of this specification are proprietary and owned exclusively by Pacific Microsonics, Inc. and are for use by authorized HDCD process licensees only. Transfer of this information to non-licensees is prohibited without the consent of Pacific Microsonics, Inc.

 , HDCD<sup>®</sup>, High Definition Compatible Digital<sup>®</sup> and Pacific Microsonics<sup>™</sup> are either registered trademarks or trademarks of Pacific Microsonics, Inc. in the United States and/or other countries.

# 1. Introduction

The HDCD<sup>®</sup> (High Definition Compatible Digital<sup>®</sup>) Equipment Certification Procedure is used to inspect and test HDCD process equipped products, submitted to Pacific Microsonics for approval, in accordance with the terms of the “Master Sales and License Agreement.” Any product incorporating HDCD decoding must pass the certification requirements defined below before being offered for sale to consumers or for evaluation by publications. Products are inspected for correct trademark and patent marking and tested for functionality. The results of the Certification Procedure are provided to the licensee as an HDCD Process Approved Equipment Certification (see attached sample). All test results are kept confidential by Pacific Microsonics. Please Note: Unless prior arrangements have been made with Pacific Microsonics, we will retain the submitted product after certification. The unit you submit to us must be electrically identical to your final production model. This requirement applies to the manual and the packaging as well.

## 1.1 Document Contents

This document contains the following sections:

HDCD Equipment Certification Procedure Descriptions	pgs. 2-10
HDCD Equipment Certification Receiving Inspection Form	pg 11
HDCD Equipment Certification Electrical Test Data Sheets	pgs. 12-20
HDCD Equipment Certification Trademark Inspection Data Sheets	pgs. 21-22
HDCD Process Certification Equipment Certification Form	pgs. 23-24
Exhibit A – Current HDCD <sup>®</sup> System Patent List	Addendum 1

# 2. Approval Requirement

Each approval category is graded on a Pass/Fail basis. A failure in any category prevents certification of the test unit. The approval categories are:

- |  |                                      |
|--|--------------------------------------|
| 1. HDCD Process Decoding Functionality | 4. Product Trademarks and Patents    |
| 2. HDCD Indicator Light Functionality  | 5. Literature Trademarks and Patents |
| 3. Overall Performance Functionality   | 6. Packaging Trademarks and Patents  |

The first three categories are functional tests, while the last three categories are visual and/or content inspections. The certification procedure for each category is described below. Testing must be scheduled with Pacific Microsonics in advance. Because of the wide variety of product types that can include HDCD decoding, written requests for modifications to these certification requirements will be considered, but must be approved in writing by Pacific Microsonics. Any approved modifications will be noted on the HDCD Process Approved Equipment Certification.

Under special circumstances, Pacific Microsonics will allow a family of products to be certified based upon a representative product passing all certification tests without requiring any certification deviations. The exact requirements for this “product family certification” will be at the sole discretion of Pacific Microsonics. Pacific Microsonics will require additional documentation from each manufacturer based upon individual requirements and intended product differences. Please see Section 4.4 of this document for a more detailed list of product family certification requirements.

## 2.1. HDCD Process Decoding Functionality

The test unit must apply proper HDCD decoding *ALWAYS* and *ONLY* with an HDCD encoded input signal. The unit must also provide proper output gain scaling between HDCD and non-HDCD encoded signal sources. Peak output level of HDCD encoded signals utilizing peak extension should be +6dB relative to the nominal output of non-HDCD encoded signals to allow for the HDCD increased dynamic range. At all decoded analog levels, units that use analog gain scaling are allowed a ±1dBr variance while those that use digital domain gain scaling are allowed a ±0.1dBr variance.

### 2.1.1. Analog Outputs

If the test unit is equipped with multiple analog outputs, then each analog output pair must be capable of meeting the above HDCD decode specifications.

### 2.1.2. Digital Outputs

If the test unit is equipped with digital outputs, then each digital output will be examined to ensure that the HDCD code is valid when HDCD encoded CD's are used in the test unit. The standard, default digital output mode should contain the standard HDCD 16 bit data. The digital output must contain **undecoded** HDCD 16 bit data when playing an HDCD CD ( i.e., an external HDCD decoder should be able to decode the digital bit stream). It is an optional feature to output **decoded** HDCD 20 bit data on the digital output. However, this must be an optional mode **ONLY** and indicated as such. This optional mode shall be referred to as "HDCD<sup>®</sup> 20 Bit Digital Output™."

## 2.2. *HDCD Indicator Light Functionality*

The test unit must indicate when HDCD processing is active by illuminating a specifically assigned indicator on the front panel of the unit. It must do so at all times when an HDCD encoded signal is presented to the unit and HDCD process decoding is being applied. It must not light when non-HDCD signals are present. The HDCD indicator may also light momentarily during power-up of the unit.

## 2.3. *Overall Performance Functionality*

The test unit should function properly in all modes of operation, including those that do not involve HDCD decoding. If failures or anomalies that negatively affect any significant aspect of a unit's operation are observed during the course of testing, the unit will not be approved for certification.

### 2.3.1. High Resolution Recording & Mini-Disc Functionality

For those products that support 88.2/96/176.4/192kHz HDCD recordings at 16, 20, or 24 bits, then appropriate HDCD encoded test material will be used to verify proper HDCD decoding, indicator illumination, and digital output code contents (if needed).





Mini-Disc Players/Recorders will be examined in the same fashion as CD Players or DVD Players. If the unit is capable of recording MD's, then that feature will be performed to ensure that the words "HDCD" are added to all track titles recorded when the source material is HDCD encoded.

### 2.3.2. HDCD Perceptual Audio Coder Recordings (Multi channel audio formats)

For those products that include both HDCD and one or more PAC formats, then this feature will be examined to ensure that the PAC decoder correctly detects the appropriate HDCD bit as described in the PAC format and illuminates the HDCD indicator.

## 2.4. *Product Trademarks and Patents*





The product must meet the following trademark, license, and patent marking requirements:

1. The  logo must be located on the front panel of the licensed unit and displayed in direct proximity to the HDCD process indicator light. When the letters HDCD are used as the HDCD process indicator in a graphic illuminated display, then the  logo can appear away from the indicator. However, the  logo must meet all of the requirements in #2 below. The  logo should be visible to anyone who uses the unit in a normal manner, easy to read, and of a size equal to other logos such as those for Dolby<sup>®</sup>, THX<sup>®</sup>, or other features,

"Dolby<sup>®</sup>" is a registered trademark of Dolby Laboratories Licensing Corp.



“THX<sup>®</sup>” is a trademark of Lucasfilm Ltd.

that the unit may possess. The HDCD<sup>®</sup> and High Definition Compatible Digital<sup>®</sup> trademarks may also appear on the front of the unit, although they are not required.

2. The trademark  logo must be a minimum of 4mm in height and **derived exactly** from the HDCD logo file supplied with the HDCD licensee materials.
3. The registered symbol <sup>®</sup> must be used with the following trademarks: HDCD<sup>®</sup>,  logo and High Definition Compatible Digital<sup>®</sup>. However, it does not have to appear with the  logo on the front panel of the licensed unit.
4. Trademark ownership must be clearly stated on the rear panel or bottom of the licensed unit as follows; “, HDCD<sup>®</sup>, High Definition Compatible Digital<sup>®</sup> and Pacific Microsonics<sup>™</sup> are either registered trademarks or trademarks of Pacific Microsonics, Inc. in the United States and/or other countries.” If there is insufficient room on the product for proper acknowledgement of the trademark ownership then a written request for a waiver of this requirement must be applied for along with documentation (i.e. engineering drawings and/or change orders) supporting this request.
5. Licensed products must acknowledge that such products are manufactured under license from Pacific Microsonics and are covered by specific patents. The following notice shall be used by the licensee on an exposed surface, such as the back panel or bottom, of all licensed products: “HDCD system manufactured under license from Pacific Microsonics, Inc. This product is covered by one or more of the following: (Insert list of patents on Exhibit A) with other patents pending.” If there is insufficient room on the product for proper acknowledgement of the license and patent ownership then a written request for a waiver of this requirement must be applied for along with documentation (i.e. engineering drawings and/or change orders) supporting this request.

## **2.5. Literature Trademarks & Other Requirements**

### **2.5.1 Product Related Literature**

The trademark and patent acknowledgements must be present on all literature (such as instruction or service manuals that accompanies the product). They must meet the applicable marking requirements for Product Trademarks above (Section 2.4). Pacific Microsonics requires that only the first use of the following trademarks: , HDCD<sup>®</sup>, High Definition Compatible Digital<sup>®</sup> and Pacific Microsonics<sup>™</sup>, contain the <sup>®</sup> registration symbol or the <sup>™</sup>. Furthermore, Pacific Microsonics requires that the trademark acknowledgement statement be present on the same page as the first use of these same trademarks. The trademark acknowledgement statement: “, HDCD<sup>®</sup>, High Definition Compatible Digital<sup>®</sup> and Pacific Microsonics<sup>™</sup> are either registered trademarks or trademarks of Pacific Microsonics, Inc. in the United States and/or other countries.” The one exception to our trademark statement requirement is the manual cover - it can display one of the trademarks: , HDCD<sup>®</sup>, High Definition Compatible Digital<sup>®</sup> without the trademark statement being on the same page of the manual.

The patent ownership acknowledgement statement must appear somewhere in the manual as well. The patent ownership acknowledgement statement is as follows: “HDCD system manufactured under license from Pacific Microsonics, Inc. This product is covered by one or more of the following: (Insert list of patents on Exhibit A). Other patents pending.”

### **2.5.2 Other Literature**

Any descriptive, instructional, advertising, or promotional literature that uses the trademarks must include the trademark acknowledgement referenced in Section 2.4 of this document.

### **2.5.3 HDCD 20 Bit Digital Output**

If the product is capable of presenting 20 bit **decoded** HDCD data on any digital output, then this additional feature of the unit must be clearly stated as “HDCD<sup>®</sup> 20 Bit Digital Output<sup>™</sup>” in all instruction or service manuals that accompanies the unit. Furthermore, this EXACT phrase must be in all literature that

accompanies the UUT: “When the \*AES3, S/P DIF, Optical digital output of the \*UUT is connected to the digital input of an external HDCD decoder, it is recommended to set the \*UUT to its default 16 bit digital output mode.” If this feature is promoted on the unit itself, the phrase “HDCD<sup>®</sup> 20 Bit Digital Output™” must also be used.

\* Choose appropriate digital output type and name.

### 2.6. Trademarks and Patent Acknowledgements on Packaging

Every effort should be made to include the trademark and patent acknowledgements on the packaging materials that accompany the product, and MUST be present if a waiver or waivers were given to product related trademarks and/or patent marking requirements. Any trademarks and trademark and/or patent acknowledgement language on the packaging must meet the applicable requirements of Section 2.4 of this document.

## 3. Inspection

Upon receipt of a unit for test, a receiving inspection is done following the procedures outlined in Section 5.1. It is at this point that Product, Packaging, and Literature Trademarks and Patent markings are inspected per the requirements detailed in the Approval Requirements.

## 4. Functionality Testing

### 4.1. Setup

The setup of the test unit is largely dependent upon the type of unit being tested, commonly either a discrete D-to-A Converter, A/V Receiver, an integrated unit with both the CD transport and D-to-A converter combined into a single package, DVD Player, or an MD Player/Recorder. The configurations described in Figure 1 (below) are designed to place the unit under test in its most commonly used mode, generally a hookup that involves a single coaxial cable connecting the unit and the remainder of what would be considered the home audiophile system.

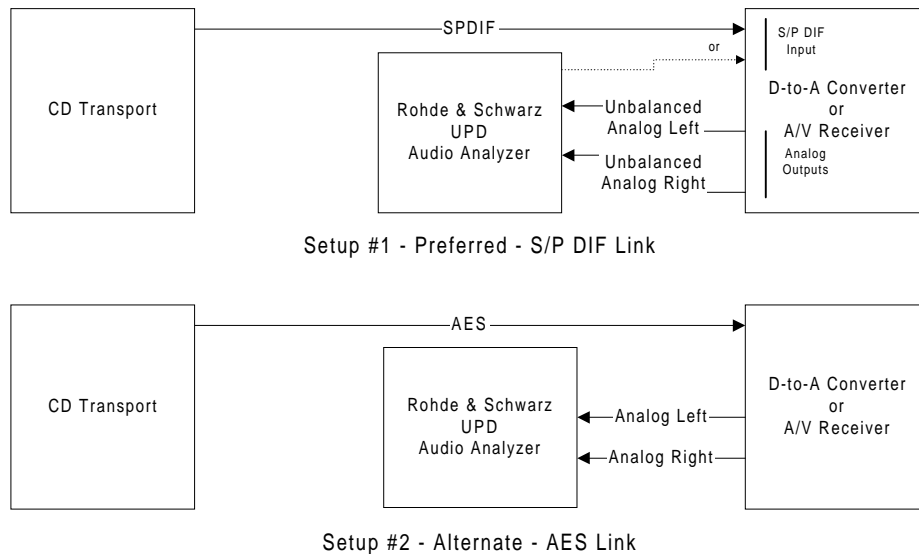

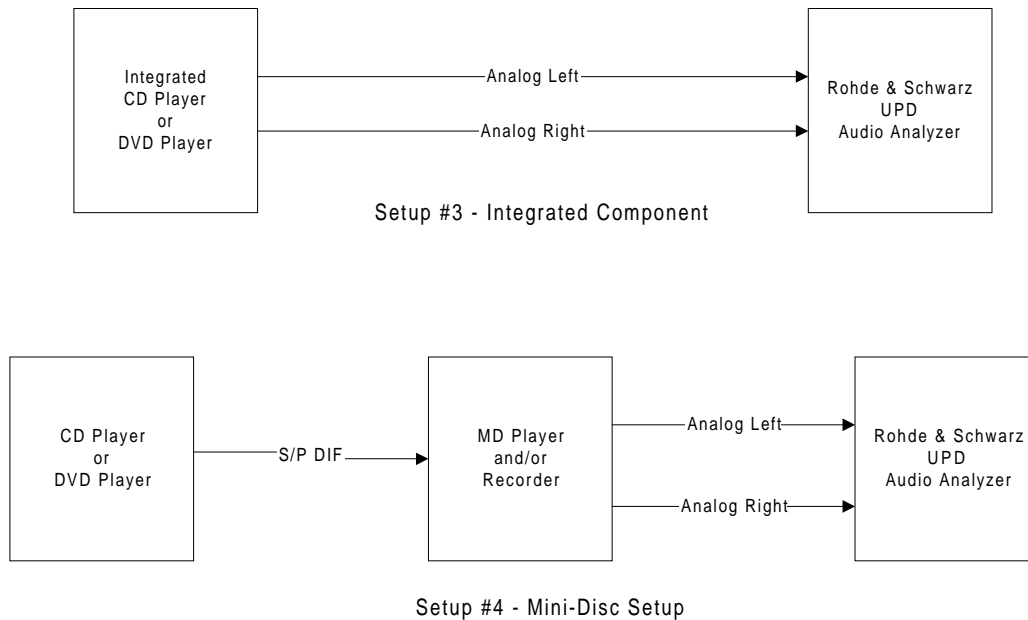

FIGURE 1

#### 4.1.1. Input/Output Configurations

While the tests below cover the basic functionality requirements, it is not considered necessary to test all of the possible combinations of inputs and outputs of the unit since this would be both time consuming, and would involve areas that are generally considered stable. Without stable interfaces the unit would probably not have passed the manufacturers internal technical or other requirements. However, PMI will examine all analog outputs for the correct decode levels. In addition, all digital outputs will be examined for proper HDCD code during playback of HDCD encoded CD's.

#### 4.1.2. Other Design Factors

The features that different manufacturer's designs incorporate can be widely varied to meet the needs of their perceived market. Such items as input and output attenuation, speaker setup, crossover control, rolloffs, etc., can be incorporated. In all cases the unit must be initially set up to provide the maximum frequency response and output level into a two speaker (R/L Stereo image) arrangement. All other processing, e.g. Dolby Surround/AC3 processing, THX, Digital Transport/interface conditioning, etc., must be disabled. Testing, as indicated in the respective procedures, will determine if there are any modes in that the units' design interferes with proper HDCD behavior. We will refer to the User's Guide provided with the unit to determine the range of these features, and how to disable/control them as required.

### 4.2. Test Disc

HDCD process functional testing requires use of the Pacific Microsonics HDCD Certification Test Disc. To facilitate both equipment design and approval processes, licensees are provided with the disc. The first ten tracks contained on the disc allow Pacific Microsonics licensees to determine if their implementation of the HDCD decode process is correct, using standard test equipment, prior to testing by Pacific Microsonics. Each track is one minute long with 3 seconds of silence between tracks. There is a 15 second pause between tracks 8 and 9.

**Warning:** These tracks are intended to be used only with instrumentation. If auditioned, there is a severe risk of transducer damage, especially with tracks 9 and 10 that have large DC offsets. The contents are as follows:

<u>Track</u>	<u>Description</u>	<u>Notes</u>
1	Non-HDCD, 0 dB FS, 1 kHz, Reference Tone	Level reference for all measurements
2	HDCD maximum steady state level, 1 kHz tone	+6.02 dB playback
3	Non-HDCD, -14dB, 1kHz tone	-13.98 dB playback
4	HDCD, -14dB, 1kHz tone, version 1	-13.98 dB playback
5	HDCD, -14dB, 1kHz tone, version 2	-13.98 dB playback
6	HDCD, -14dB, 1kHz tone, version 3	-13.98 dB playback
7	Non-HDCD, -74dB, 997 Hz tone	-73.98 dB playback
8	HDCD, -74dB, 997 Hz tone	-73.98 dB playback
9	HDCD special DC test, version 1	Should have no AC components other than dither
10	HDCD special DC test, version 2	Should have no AC components other than dither

All tracks incorporate high-frequency weighted dither with an energy spectrum above the audio range. Tracks 4, 9, and 10 were recorded without HDCD peak extension. The HDCD indicator light should be on during tracks 2, 4, 5, 6, 8, 9, & 10. The light should turn off 1 second after the loss of the HDCD process signal. It is normal for the light to flash briefly when power is first applied to the PMD-100 chip.

PLEASE NOTE: There are additional test tracks on the HDCD Certification Test Disc that are not used in the certification process. For a full description of these test tracks, please refer to the HDCD Certification Test Disc Application Note.

### 4.3. **Functionality Tests**

The purpose of each functionality test is outlined in the sections that follow. Step by step procedures are detailed in Section 5.

#### 4.3.1. **Calibration**

**Purpose:** Many of the required test measurements are relative in nature and refer to a standard reference signal. Track #1 provides a calibrated non-HDCD format 0dB Full Scale reference tone at 1kHz that is used as a standard throughout the test process. If the unit has reached a stable operating temperature prior to testing, it should only be necessary to perform calibration of the test unit and test equipment once. There are several points in the test process where any observed deviations from the calibrated levels must be noted.

**Procedure:** See Section 5.2 of this document for the associated procedure and data sheet.

#### 4.3.2. **Test #1 – Audio Polarity**

**Purpose:** This test is used to determine if HDCD encoded materials are properly decoded regardless of the absolute phase (polarity) of the test unit. The Raised Cosine test on the JAS Test CD-1 (Track #88) is used to evaluate test units both in Normal and Inverted polarity. If the test unit has no polarity inversion capability, the latter portion of the test will be disregarded.

**Procedure:** See Section 5.3 of this document for the procedure and data sheet that implement this test.

#### 4.3.3. **Test #2 – HDCD Decoding and Gain Switching**

**Purpose:** This test employs track #2 of the HDCD Test Disc. It is used to determine if HDCD encoded signals are properly decoded with respect to the analog signal output level. HDCD encoded signals are decoded to a level that is 6dB higher than non-HDCD signals. This provides matching of average audio levels between the two sources, allowing for the increased dynamic range of HDCD signals. Tighter tolerances are required for units using digital gain control ( $\pm 0.1$ dB) as opposed to those using analog gain switching ( $\pm 1$ dB).

**Procedure:** See Section 5.4 of this document for the procedure and data sheet that implement this test.

**4.3.4. Test #3 – Non-HDCD: 1kHz @ -14dB Level**

**Purpose:** This test employs track #3 of the HDCD Test Disc. It is used to insure that non-HDCD encoded signals of average level are properly processed with respect to the analog signal output level.

**Procedure:** See Section 5.5 of this document for the procedure and data sheet that implement this test.

**4.3.5. Test #4 – HDCD: 1kHz @ -14dB Level, Version 1**

**Purpose:** This test employs track #4 of the HDCD Test Disc. It is used to determine if HDCD encoded signals of average level are properly decoded with respect to the analog signal output level. This test uses the first of three versions of encoding such a signal.

**Procedure:** See Section 5.6 of this document for the procedure and data sheet that implement this test.

**4.3.6. Test #5 – HDCD: 1kHz @ -14dB Level, Version 2**

**Purpose:** This test employs track #5 of the HDCD Test Disc. It is used to determine if HDCD encoded signals of average level are properly decoded with respect to the analog signal output level. This test uses the second of three versions of encoding such a signal.

**Procedure:** See Section 5.7 of this document for the procedure and data sheet that implement this test.

**4.3.7. Test #6 – HDCD: 1 kHz @ -14dB Level, Version 3**

**Purpose:** This test employs track #6 of the HDCD Test Disc. It is used to determine if HDCD encoded signals of average level are properly decoded with respect to the analog signal output level. This test uses the third of three versions of encoding such a signal.

**Procedure:** See Section 5.8 of this document for the procedure and data sheet that implement this test.

**4.3.8. Test #7 – Non-HDCD: 997 Hz @ -74dB Level**

**Purpose:** This test employs track #7 of the HDCD Test Disc. It is used to insure that non-HDCD encoded signals of low signal level are properly processed with respect to the analog signal output level.

**Procedure:** See Section 5.9 of this document for the procedure and data sheet that implement this test.

**4.3.9. Test #8 – HDCD: 997Hz @ -74dB Level**

**Purpose:** This test employs track #8 of the HDCD Test Disc. It is used to determine if HDCD encoded signals of low signal level are properly decoded with respect to the analog signal output level.

**Procedure:** See Section 5.10 of this document for the procedure and data sheet that implement this test.

**4.3.10. Test #9 – HDCD: DC w/100Hz @ -110dB Level**

**Purpose:** This test employs track #9 of the HDCD Test Disc. It is used to determine if HDCD encoded DC signals are properly decoded. In addition to dither, there may be a trace of 100Hz at  $\leq -110$ dB embedded within the signal. This test is only to be run with programmable DSP based HDCD implementations.

**Procedure:** See Section 5.11 of this document for the procedure and data sheet that implement this test.

**4.3.11. Test #10 – HDCD: DC w/50 Hz @ -110dB Level**

**Purpose:** This test employs track #10 of the HDCD Test Disc. It is used to determine if HDCD encoded DC signals are properly decoded. In addition to dither, there may be a trace of 50Hz at  $\leq -110$ dB embedded within the signal. This test is only to be run with programmable DSP based HDCD implementations.

**Procedure:** See Section 5.12 of this document for the procedure and data sheet that implement this test.

#### **4.3.12. Test #11 – Narrow Band Harmonics**

**Purpose:** This test is used to observe the harmonic content of the test unit when the generator is set to deliver a 1kHz tone.

**Procedure:** See Section 5.13 of this document for the procedure and data sheet that implement this test.

#### **4.3.13. Test #12 – Wide Band Harmonics**

**Purpose:** This test is used to observe the harmonic content of the test unit when the generator is set to deliver a 1kHz tone. This test provides a 300 kHz display and test bandwidth, allowing a direct observation of the test unit's out-of-band harmonic performance. This test is useful for determining the type and effect of dither that the test unit is using.

**Procedure:** See Section 5.14 of this document for the procedure and data sheet that implement this test.

#### **4.3.14. Test #13 – Digital Output Tests**

**Purpose:** This test is used when there are digital outputs on the test unit – either S/P DIF, Optical, or AES3. In all cases, all digital outputs will be examined for proper operation with respect to the HDCD code during playback of HDCD encoded CD's. Refer to section 2.1 for a detailed description of the HDCD code requirements made available externally.

**Procedure:** See section 5.15 of this document for the procedure and data sheet that implement this test.

#### **4.3.15. Test #14 – High Resolution HDCD Recordings Tests**

**Purpose:** This test is performed if the unit is capable of accepting high resolution HDCD recordings (via either direct playback or digital input). The appropriate HDCD test material will be used to determine if the unit correctly decodes and activates the HDCD indicator.

**Procedure:** See Section 5.16 of this document for the procedure and data sheet that implement this test.

#### **4.3.16. Test #15 – Mini-Disc Tests**

**Purpose:** This test is performed when the unit under test is an MD Player and/or Recorder. The unit will be tested for proper decoding and HDCD indicator functions. In conjunction with a CD Player (if indicated), the recorder unit will be used to record several tracks of HDCD encoded material to verify that it correctly adds to the track title the word "HDCD." If the unit is equipped with digital outputs, then they will be examined as in Section 4.3.14.

**Procedure:** See Section 5.17 of this document for the procedure and data sheet that implement this test.

#### **4.3.17. Test #16 – HDCD PAC Test**

**Purpose:** This test is performed when the unit under test is capable of decoding PAC (perceptual audio coder) formats. HDCD encoded material will be played back and the unit under test will be examined to determine if it is capable of properly decoding the HDCD bit and illuminating the HDCD Indicator. In addition, the status of HDCD Filtering in this implementation will be examined.

**Procedure:** See Section 5.18 of this document for the procedure and data sheet that implement this test.

#### **4.3.18. Test #17 – Frequency Response (optional)**

**Purpose:** This optional test is used to observe the high-to-low swept frequency response of the unit in the 20-20kHz audio band. Note that this test is used for observational purposes only and has no bearing on the Pass/Fail criteria of equipment approval.

**Procedure:** See Section 5.19 of this document for the procedure and data sheet that implement this test.

#### **4.3.19. Test #18 – Output Coupling (optional)**

**Purpose:** This optional test is similar to Test #1 – Audio Polarity, but use a DC-coupled scope to view the output of the unit (the Rohde and Schwarz is always AC-coupled). If the waveform flips about an axis between the min and max values of the polarity test signal it is an AC-coupled system. DC-coupled outputs will flip about the baseline of the test waveform (or very nearly given that a minimum of a DC offset is commonly present). Note that this test is used for observational purposes only and has no bearing on the Pass/Fail criteria of equipment approval.

**Procedure:** See Section 5.20 of this document for the procedure and data sheet that implement this test.

#### **4.4. Product Family Certification Requirements**

Pacific Microsonics will allow a family of products to be certified based upon minor differences that exists within each manufacturers product line AND the level/type of differences from a representative product already certified. In such cases, Pacific Microsonics will require additional documentation (i.e., Engineering Change Notices, Production Assembly Drawings, Mechanical Drawings, etc) in enough detail that exactly outlines the planned differences between the new product(s) and the currently certified product for our review. In addition, Pacific Microsonics will require from the manufacturer a signed letter from an authorized company representative specifically stating the new product(s) differences.

Based upon an examination of all documentation provided by the manufacturer, Pacific Microsonics will issue a new product certification form for the new product(s) based upon the number and type of new products and will attach the company letter to it. This Pacific Microsonics document package will reference the original product certified and a copy of this package will be on file at Pacific Microsonics along with all relevant manufacturer’s documentation. A copy of this document package will be forwarded to the manufacturer for their files. Deviations from the Product Family Certification Requirements will be decided on a case by case basis at the sole discretion of Pacific Microsonics.

### **5. Test Procedures and Data Sheets**

The following pages contain the incoming inspection sheet, the test procedures and data sheets that implement the functional test plan indicated earlier in this document.

**5.1. Equipment Approval Receiving Inspection**

<b>Equipment Approval Receiving Inspection Report</b>	
Date Received: _____ Number of Packages: _____ Received By: _____  Manufacturer: _____ Model: _____	Open and inspect as soon as it is received to note the contents and any damage or other conditions that may affect the equipment approval process. Note this and other indicated information below.  Unit Type: _____ Serial #: _____
<b>Receiving Inspection</b>	
<u>Item Received</u> <input type="checkbox"/> Unit <input type="checkbox"/> Power Supply <input type="checkbox"/> Operators Guide and/or Manuals <input type="checkbox"/> Remote Control..... <input type="checkbox"/> Wireless..... <input type="checkbox"/> Wired <input type="checkbox"/> Batteries <input type="checkbox"/> AC Line Cord <input type="checkbox"/> Digital Audio Cable(s) <input type="checkbox"/> Analog Audio Cable(s) <input type="checkbox"/> Other Accessories 1. _____ 2. _____	<u>Condition on receipt</u> _____ List: _____ Type/Count _____ _____ _____ _____ _____
<u>UUT Configuration</u>	
Record the UUT's Inputs: <u>Digital</u> <input type="checkbox"/> AES3 <input type="checkbox"/> S/P DIF <input type="checkbox"/> Optical <input type="checkbox"/> XLR <input type="checkbox"/> BNC <input type="checkbox"/> RCA <u>Analog</u> <input type="checkbox"/> XLR (bal) <input type="checkbox"/> RCA (unbal)	Record the UUT's Outputs: <u>Digital</u> <input type="checkbox"/> AES3 <input type="checkbox"/> S/P DIF <input type="checkbox"/> Optical <input type="checkbox"/> XLR <input type="checkbox"/> BNC <input type="checkbox"/> RCA <u>Analog</u> <input type="checkbox"/> XLR (bal) <input type="checkbox"/> RCA (unbal)

**5.2. Initial Calibration**

Test Data Sheet: Initial Calibration				
	Action	Data		
1	Connect the digital output from the CD player to the digital input on the unit (if necessary).			
2	Connect the analog outputs from the UUT to the ANALYZER inputs on the Rohde & Schwarz.			
3	<i>Load Setup File D2AFFTAB.SCO</i> Select FILE menu, select file D2AFFTAB.SCO. Configures the Analyzer for absolute readings.			
4	Start HDCD Test Disc Track #1. Non-HDCD 0dBfs 1kHz Reference.			
5	Note the HDCD indicator status. Must be OFF.	<input type="checkbox"/> HDCD <input type="checkbox"/> Non-HDCD		
6	Record the relative RMS and Peak levels of the UUT.	<u>Channel 1</u> RMS Level: Peak Level: <u>Channel 2</u> RMS Level: Peak Level:		
7	<i>Load Setup File D2AFFT.SAC.</i> 6.1 Select FILE menu, • Mode – ACT SETUP. 6.2 Select D2AFFT.SAC Sets up for relative readings (in dBr relative to reference).			
8	Calibrate the ANALYZER to the UUTs Output levels. 6.3 Select each of the three VALUE fields on the ANALYZER display and choose the STORE CH 1 option.  - Activate the selection using the ENTER key. This should leave a 0dBr reading on the RMS via FFT display.			
9	Record the UUT’s RMS and Peak levels. Should be ~ 0dBr.	<u>Channel 1</u> RMS Level: Peak Level: <u>Channel 2</u> RMS Level: Peak Level:		
10	Record the noise floor level @ 1kHz from the FFT for both channels. Should be below -100dB, varies with quality of design.	<u>Channel 1</u> Level: <u>Channel 2</u> Level:		

**5.3. Test #1 – Audio Polarity**

Test Data Sheet: Audio Polarity				
	Action	Data		
1	<i>Load Setup File D2AFFT.SAC on the R&amp;S</i> Load PMI Test Disc Track 20 (left channel)			
2	Select Non-Inverted output mode on the UUT.			
3	Record the HDCD indicator status. Should be OFF.	<input type="checkbox"/> HDCD <input type="checkbox"/> Non-HDCD		
4	Select ANLR menu, change II FUNCTION-WAVEFORM, and • Trig Slope – RISING. Observe the waveform. Record the nature of each channels output. Repeat using Track 21 (right channel).	<u>Channel 1</u> <input type="checkbox"/> Non-Inverted <input type="checkbox"/> Inverted <u>Channel 2</u> <input type="checkbox"/> Non-Inverted		

		<input type="checkbox"/> Inverted			
5	Select Inverted output mode on the UUT. If no inverted mode available go to Test 5.4.				
6	Select ANLR menu, $\Pi$ FUNCTION-WAVEFORM, and change • Trig Slope – FALLING. Observe the waveform. Record the nature of each channels output. Repeat using Track 20.	<u>Channel 1</u> <input type="checkbox"/> Non-Inverted <input type="checkbox"/> Inverted <u>Channel 2</u> <input type="checkbox"/> Non-Inverted <input type="checkbox"/> Inverted			
7	Record the HDCD indicator status. Should be OFF.	<input type="checkbox"/> HDCD <input type="checkbox"/> Non-HDCD			
8	Go to Track 2 of the PMI Test Disc.				
9	Record the HDCD indicator status. Should be ON.	<input type="checkbox"/> HDCD <input type="checkbox"/> Non-HDCD			
10	Select Non-Inverted output mode on the UUT.				
11	Record the HDCD indicator status. Should be ON. Select ANLR menu and change $\Pi$ FUNCTION-FFT	<input type="checkbox"/> HDCD <input type="checkbox"/> Non-HDCD			

**5.4. Test #2 – HDCD Decoding and Gain Switching**

Test Data Sheet: HDCD Decoding and Gain Switching					
	Action	Data			
1	Load Setup File D2AFFT.SAC and recalibrate the Analyzer to Test Disc Track #1. Start Track 2.				
2	Start the test stimulus: HDCD Test Disc Track #2 An HDCD encoded maximum level steady state signal tone at 1kHz is generated.				
3	Select Non-Inverted on the unit.				
4	Note the HDCD indicator status. Should be ON.	<input type="checkbox"/> HDCD <input type="checkbox"/> Non-HDCD			
5	Record the relative RMS and Peak levels of the UUT. Output must be +6.02dBr. Units using analog-domain gain switching/attenuation are allowed $\pm 1$ dB variance. Units using digital-domain gain controls should be within $\pm 0.1$ dB.	<u>Channel 1</u> RMS Level: Peak Level: <u>Channel 2</u> RMS Level: Peak Level:			
6	Record the noise floor @ 1kHz for each channel from the FFT. Should see the NF rise +10-15dB relative to initial calibration.	<u>Channel 1</u> Level:  <u>Channel 2</u> Level:			
7	Select Inverted output on the unit. If no inverted mode available go to Test 5.5.				
8	Note the HDCD indicator status. Should be ON.	<input type="checkbox"/> HDCD <input type="checkbox"/> Non-HDCD			
9	Record the relative RMS and Peak levels of the UUT. Should see both channels at +6.02dBr referenced to Track 1.	<u>Channel 1</u> RMS Level: Peak Level: <u>Channel 2</u> RMS Level: Peak Level:			
10	Select Track #1. Record the relative RMS and Peak levels of the UUT. Should observe both channels at 0dBr referenced to Track 1.	<u>Channel 1</u> RMS Level: Peak Level: <u>Channel 2</u> RMS Level: Peak Level:			

**5.5. Test #3 – Non-HDCD 1kHz @ -14dB Level**

Test Data Sheet: Non-HDCD 1kHz Tone, -14dB					
	Action	Data			
1	Use Setup File D2AFFT.SAC with Track 3.				
2	Select Non-Inverted output mode on the unit.				
3	Record the HDCD indicator Status. Should be OFF.	<input type="checkbox"/> HDCD <input type="checkbox"/> Non-HDCD			
4	Observe the relative RMS and Peak levels of the output of the unit and record. Should see both channels at -14dBr, relative to the initial calibration.	<u>Channel 1</u> RMS Level: Peak Level:  <u>Channel 2</u> RMS Level: Peak Level:			
5	Record the noise floor level @ 1kHz for each channel from the FFT. Should be equal to those seen in Step 10 of the initial calibration.	<u>Channel 1</u> Level: <u>Channel 2</u> Level:			

**5.6. Test #4 – HDCD 1kHz @ -14dB Level, Version 1**

Test Data Sheet: HDCD 1kHz Tone, -14dB, Version 1					
	Action	Data			
1	Use Setup File D2AFFT.SAC with Track 4.				
2	Select Non-Inverted output mode on the unit.				
3	Record the HDCD indicator Status. Should be ON.	<input type="checkbox"/> HDCD <input type="checkbox"/> Non-HDCD			
4	Observe the relative RMS and Peak levels of the output of the unit and record. Should see both channels at -14dBr, relative to the initial calibration.	<u>Channel 1</u> RMS Level: Peak Level:  <u>Channel 2</u> RMS Level: Peak Level:			
5	Note the noise floor level @ 1kHz for each channel from the FFT and record. Should be below those seen in Step 10 of the initial calibration.	<u>Channel 1</u> Level: <u>Channel 2</u> Level:			

**5.7. Test #5 – HDCD 1kHz @ -14dB Level, Version 2**

Test Data Sheet: HDCD 1kHz Tone, -14dB, Version 2					
	Action	Data			
1	Use Setup File D2AFFT.SAC with Track 5.				
2	Select Non-Inverted output mode on the unit.				
3	Record the HDCD indicator status. Should be ON.	<input type="checkbox"/> HDCD <input type="checkbox"/> Non-HDCD			
4	Observe the relative RMS and Peak levels of the output of the unit and record. Should see both channels at -14dBr, relative to the initial calibration.	<u>Channel 1</u> RMS Level: Peak Level: <u>Channel 2</u> RMS Level: Peak Level:			
5	Note the noise floor level @ 1kHz for each channel from the FFT and record. Should be below those seen in Step 10 of the initial calibration.	<u>Channel 1</u> Level: <u>Channel 2</u> Level:			

**5.8. Test #6 – HDCD 1kHz @ -14dB Level, Version 3**

Test Data Sheet: HDCD 1kHz Tone, -14dB, Version 3					
	Action	Data			
1	Use Setup File D2AFFT.SAC with Track 6.				
2	Select Non-Inverted output mode on the unit.				
3	Record the HDCD indicator status. Should be ON.	<input type="checkbox"/> HDCD <input type="checkbox"/> Non-HDCD			
4	Observe the relative RMS and Peak levels of the output of the unit and record. Should see both channels at -14dBr, relative to the initial calibration.	<u>Channel 1</u> RMS Level: Peak Level: <u>Channel 2</u> RMS Level: Peak Level:			
5	Note the noise floor level @ 1kHz for each channel from the FFT and record. Should be below those seen in Step 10 of the initial calibration.	<u>Channel 1</u> Level: <u>Channel 2</u> Level:			

**Test #7 – Non-HDCD 997Hz @ -74dB Level**

Test Data Sheet: Non-HDCD 997Hz @ -74dB Level					
	Action	Data			
1	Use Setup File D2AFFT.SAC with Track 7				
2	Select Non-Inverted output mode on the unit.				
3	Record the HDCD indicator status. Should be OFF.	<input type="checkbox"/> HDCD <input type="checkbox"/> Non-HDCD			
4	Observe the relative RMS and Peak levels of the output of the unit and record. Should see both channels at -74dBr, relative to the initial calibration.	<u>Channel 1</u> RMS Level: Peak Level: <u>Channel 2</u> RMS Level: Peak Level:			
5	Note the noise floor level @ 1kHz for each channel from the FFT and record. Should be below those seen in Step 10 of the initial calibration.	<u>Channel 1</u> Level: <u>Channel 2</u> Level:			

**5.9. Test #8 – HDCD 997Hz @ -74dB Level**

Test Data Sheet: HDCD 997Hz @ -74dB Level					
	Action	Data			
1	Use Setup File D2AFFT.SAC with Track 8.				
2	Select Non-Inverted output mode on the unit.				
3	Record the HDCD indicator status. Should be OFF.	<input type="checkbox"/> HDCD <input type="checkbox"/> Non-HDCD			
4	Observe the relative RMS and Peak levels of the output of the unit and record. Should see both channels at -74dBr, relative to the initial calibration.	<u>Channel 1</u> RMS Level: Peak Level: <u>Channel 2</u> RMS Level: Peak Level:			
5	Note the noise floor level @ 1kHz for each channel from the FFT and record. Should be below those seen in Step 10 of the initial calibration.	<u>Channel 1</u> Level: <u>Channel 2</u> Level:			

**5.10. Test #9 – HDCD: DC w/ 100Hz @ -110dB Level (Programmable DSP Based Implementation ONLY)**

Test Data Sheet: HDCD: DC w/ 100 Hz @ -110dB Level	
Action & Observations	
1	Use Setup File D2AFFT.SAC
2	Start the test stimulus: PMI HDCD Process Test Disc Track #9: HDCD Special DC Test, Version 1. An HDCD encoded steady state 100 Hz DC signal at -110dB is generated.
3	Observe the noise floor for each channel from the FFT. The noise at 15 to 20 kHz is dither created by the PMD-100. Note your observations below, in particular, the peak areas above the average noise floor level.

**5.11. Test #10 – HDCD:DC w/ 50 Hz @ -110dB Level (Programmable DSP Based Implementation ONLY)**

Test Data Sheet: HDCD: DC w/ 50 Hz @ -110dB Level	
Action & Observations	
1	Use Setup File D2AFFT.SAC
2	Start the test stimulus: PMI HDCD Process Test Disc Track #10: HDCD Special DC Test, Version 2. An HDCD encoded steady state 50 Hz DC signal at -110dB is generated.
3	Observe the noise floor for each channel from the FFT. The noise at 15 to 20 kHz is dither created by the PMD-100. Note your observations below, in particular, the peak areas above the average noise floor level.

**5.12. Test #11 –Narrow Band Harmonics Tests**

Action & Observations	
1	Use Setup File D2AFFT.SAC
2	Start the test stimulus: PMI HDCD Process Test Disc Track #1. A non-HDCD encoded, 1 kHz, 0 dB reference signal is generated.
3	Observe the harmonic content of the unit. Note your observations below, in particular, the harmonic peaks above the average noise floor level.

**5.13. Test #12 – Wide Band Harmonics**

Test Data Sheet: Wide Band Harmonics	
Action & Observations	
1	Use Setup File D2AFFTWD.SAC. This setup provides a 300 kHz display and test bandwidth, allow a direct observation of the unit out-of-band harmonic performance. This setup is useful for determining the effect and type of dither that the unit is using at any particular moment.
2	Start the test stimulus: PMI HDCD Process Test Disc Track #1. A non-HDCD encoded, 1 kHz, 0 dB reference signal is generated. Calibrate the ANALYZER to the reference signal.
3	Observe the harmonic content of the unit. Note your observations below, in particular, the harmonic peaks above the average noise floor level.

**5.14. Test #13 – Digital Output Tests**

Action & Observations	
1	Record the UUT’s digital output options: <input type="checkbox"/> S/P DIF <input type="checkbox"/> Optical <input type="checkbox"/> AES3 <input type="checkbox"/> HDCD-16 <input type="checkbox"/> HDCD-20
2	Verify that the UUT has HDCD-16 as the default digital output code: <input type="checkbox"/> YES <input type="checkbox"/> NO
3	Verify the accuracy and number of bits in the HDCD 16/20 bit code: <input type="checkbox"/> PASS <input type="checkbox"/> FAIL

**5.15. Test #14 – High Resolution HDCD Recording Tests**

Action & Observations	
1	Record the UUT’s High Resolution HDCD options: <input type="checkbox"/> 88.2kHz <input type="checkbox"/> 96kHz <input type="checkbox"/> 176.4kHz <input type="checkbox"/> 192kHz <input type="checkbox"/> HDCD-16 <input type="checkbox"/> HDCD-20 <input type="checkbox"/> HDCD-24
2	Does the UUT contain High Resolution HDCD Filtering: <input type="checkbox"/> YES <input type="checkbox"/> NO
3	Verify that the UUT properly decodes the HDCD test tracks: <input type="checkbox"/> YES <input type="checkbox"/> NO
4	Verify that the UUT correctly illuminates the HDCD indicator: <input type="checkbox"/> PASS <input type="checkbox"/> FAIL

**5.16. Test #15 – Mini-Disc Tests**

Action & Observations	
1	Record the UUT’s Mini-Disc Player Type: <input type="checkbox"/> Player Only <input type="checkbox"/> Player/Recorder
2	Verify that the UUT properly decodes HDCD test tracks: <input type="checkbox"/> YES <input type="checkbox"/> NO
3	Verify that the UUT correctly illuminates the HDCD indicator: <input type="checkbox"/> PASS <input type="checkbox"/> FAIL

**5.17. Test #16 – HDCD PAC Tests**

Action & Observations	
1	Record the UUT’s PAC Player Type:
2	Does the UUT contain HDCD Filtering: <input type="checkbox"/> YES <input type="checkbox"/> NO
3	Verify that the UUT correctly illuminates the HDCD indicator: <input type="checkbox"/> PASS <input type="checkbox"/> FAIL

**5.18. Test #17 – Frequency Response (optional)**

Test Data Sheet: Frequency Response	
Action & Observations	
1	Use Setup File D2ASWP.SAC and start the analyzer. This setup displays the high-to-low swept frequency response of the unit in the 20-20kHz audio band.
2	Start the test stimulus: PMI HDCD Process Test Disc Track #1. A non-HDCD encoded, 1 kHz, 0 dB reference signal is generated. Calibrate the ANALYZER to the reference signal.
3	Using SINGLE SWEEP MODE, note your observations below. (You may want to change display ■ OPERATION to SPECTR LIST to get min and max values.)

**5.19. Test #18 – Output Coupling (optional)**



Test Data Sheet: Output Coupling	
Action & Observations	
1	Perform Test #1 – Audio Polarity, but use a DC-coupled scope to view the output of the unit (the Rohde and Schwarz is always AC-coupled). If the waveform flips about an axis between the min and max values of the polarity test signal it is an AC-coupled system. DC-coupled outputs will flip about the baseline of the test waveform (or very nearly given that a minimum of a DC offset is commonly present).
2	Note your observations below.



**6. HDCD Equipment Approval Trademark and Patent Marking Inspection Data Sheet**

**6.4 HDCD Logo**

Verify that the logo for the following inspections looks like;



Inspection Data Sheet: Product Trademarks and Patents	
Action & Observations	
1	Visually inspect the unit under test (UUT). Verify that the front panel  logo is <b>EXACTLY</b> reproduced. Measure the overall height of the logo. It <b>MUST</b> be a minimum of 4 millimeters high. The words High Definition Compatible Digital are acceptable if used on the front panel. NOTE: the registered symbol ® does not have to appear with the trademark on the front panel.  <input type="checkbox"/> Pass <input type="checkbox"/> Fail
2	Visually inspect the UUTs front panel. Verify that the HDCD indicator is in close proximity to the  logo (if the letters “HDCD” are part of an illuminated display, then verify that the  logo is present on the front panel only) as in Section 2.4.  <input type="checkbox"/> Pass <input type="checkbox"/> Fail
3	If the UUT is capable of producing 20 bit decoded HDCD data on any digital output and this feature is promoted on the unit itself, verify that the words “HDCD® 20 Bit Digital Output™” are used.  <input type="checkbox"/> Pass <input type="checkbox"/> Fail

4	<p>Visually inspect either the rear panel or the bottom of the UUT. Verify that the following acknowledgement is clearly stated: “, HDCD®, High Definition Compatible Digital® and Pacific Microsonics™ are either registered trademarks or trademarks of Pacific Microsonics, Inc. in the United States and/or other countries.” Either HDCD or the  logo is inserted with the registered symbol ® and/or the words High Definition Compatible Digital are inserted with the registered symbol ®.</p> <p style="text-align: right;"><input type="checkbox"/> Pass      <input type="checkbox"/> Fail</p>
5	<p>Visually inspect either the rear panel or the bottom of the UUT. Verify that the following statement is clearly stated: “HDCD system manufactured under license from Pacific Microsonics, Inc. This product is covered by one or more of the following: (Verify the list of patents on Exhibit A is inserted). Other patents pending.”</p> <p style="text-align: right;"><input type="checkbox"/> Pass      <input type="checkbox"/> Fail</p>

<b>Inspection Data Sheet: Literature Trademarks and Patents</b>	
Action & Observations	
1	<p>Visually inspect the instruction or service manual that is shipped with the UUT. Verify that the trademarks are <b>EXACTLY</b> reproduced. Measure the overall height of the logo. It <b>MUST</b> be a minimum of 4 millimeters high. Verify that the first occurrence (the only exception is the manual cover) of any Pacific Microsonics trademark has the registered symbol ® and contains the following statement somewhere on the same page: “, HDCD®, High Definition Compatible Digital® and Pacific Microsonics™ are either registered trademarks or trademarks of Pacific Microsonics, Inc. in the United States and/or other countries.”</p> <p style="text-align: right;"><input type="checkbox"/> Pass      <input type="checkbox"/> Fail</p>
2	<p>Visually inspect the instruction or service manual that ships with the UUT. Verify that the following statement is clearly stated somewhere in the manual: “HDCD system manufactured under license from Pacific Microsonics, Inc. This product is covered by one or more of the following: (Verify the list of patents on Exhibit A is inserted). Other patents pending.”</p> <p style="text-align: right;"><input type="checkbox"/> Pass      <input type="checkbox"/> Fail</p>
3	<p>If the UUT is capable of producing 20 bit decoded HDCD data on any digital output, then verify that the words “HDCD® 20 Bit Digital Output™” are used In the instruction or service manual that ships with the UUT.</p> <p style="text-align: right;"><input type="checkbox"/> Pass      <input type="checkbox"/> Fail</p>
4	<p>Visually inspect the instruction or service manual that is shipped with the UUT. If the UUT is capable of producing 20 bit decoded HDCD data on any digital output, then verify that the following phrase is present: “The AES3/S/P DIF/Optical digital output of the UUT is connected to the AES3/S/P DIF/Optical digital input of an external HDCD decoder, it is recommended to set the UUT to its default SPDIF 16 bit digital output mode.”</p> <p style="text-align: right;"><input type="checkbox"/> Pass      <input type="checkbox"/> Fail</p>

<b>Inspection Data Sheet: Packaging Trademarks and Patents</b>	
Action & Observations	
1	<p>Visually inspect the packaging materials. The trademark and patent acknowledgements should be on the packaging materials that accompany the product, and <b>MUST</b> be present if a waiver or waivers were given to product related trademarks and/or patent marking requirements. Any trademarks, and trademark and/or patent acknowledgement language on the packaging must meet the applicable size and language requirements. If there are third party technology trademarks on the packaging, verify that the HDCD trademarks are on the packaging materials and are at least of equal size to the other parties’ trademarks.</p> <p style="text-align: right;"><input type="checkbox"/> Pass      <input type="checkbox"/> Fail</p>

## 7. HDCD Process Approved Equipment Certification

The certification form is contained on the following two pages. The original is to remain with this report. A copy should be forwarded to the equipment manufacturer and/or designer for proof of certification. Please refer to Sections 2.1 through 2.6 for descriptions of inspection/test criteria used on the certification form.

## HDCD<sup>®</sup> PROCESS APPROVED EQUIPMENT CERTIFICATION

Manufacturer: \_\_\_\_\_

Product Name: \_\_\_\_\_

Product Type: \_\_\_\_\_

Sample Serial No.: \_\_\_\_\_

Date of Test: \_\_\_\_\_

*Manufacturer certifies that submitted sample is fully representative of production product in terms of function and appearance. Any approved exceptions are as follows:*

\_\_\_\_\_  
\_\_\_\_\_  
\_\_\_\_\_

### FUNCTIONAL TESTS

(Circle One)

1) HDCD Process Decoding:                      PASS                      FAIL

Comments: \_\_\_\_\_  
\_\_\_\_\_

2) HDCD Indicator Light:                      PASS                      FAIL

Comments: \_\_\_\_\_  
\_\_\_\_\_

3) Overall Performance:                      PASS                      FAIL

Comments: \_\_\_\_\_  
\_\_\_\_\_

**TRADEMARK AND PATENT MARKINGS INSPECTIONS**

4) Product Trademarks and Patents: PASS FAIL

Comments: \_\_\_\_\_  
\_\_\_\_\_

5) Literature Trademarks and Patents: PASS FAIL

Comments: \_\_\_\_\_  
\_\_\_\_\_

6) Packaging Trademarks and Patents: PASS FAIL

Comments: \_\_\_\_\_  
\_\_\_\_\_

According to the above results, the submitted sample *PASSED* or *FAILED* (Circle One) the requirements to be offered for sale as HDCD Process Approved Equipment.

By: \_\_\_\_\_ Date: \_\_\_\_\_  
Engineering

By: \_\_\_\_\_ Date: \_\_\_\_\_  
Corporate

EXHIBIT A  
CURRENT HDCD® System PATENT LIST

Country	Patent No.
United States	5,479,168
	5,638,074
	5,640,161
	5,808,574
	5,838,274
	5,854,600
	5,864,311
5,872,531	
Australia	669114